

Frequency converters
EFC 3600



Frequency converters

EFC 3600

Documentation



- Compact and complete: space saving side-by-side assembly, plug-in I/O terminals, with brake chopper and mains filter for ultra-simple installation and integration
- Simply practical: removable operator panel with storage function, straightforward parameter inputs, harmonized parameters for the entire series to save time and improve quality during series start-up
- Maximized energy efficiency and minimized motor noises through continuously adjustable pulse frequency

The Rexroth EFC 3600 frequency converter is the compact, cost-efficient, and energy-efficient drive solution for the performance range from 0.4 kW to 4 kW. Easy commissioning and installation enable a wide range of applications.

Technical data

		EFC3600-0K40-1P2	EFC3600-0K75-1P2	EFC3600-1K50-1P2	EFC3600-2K20-1P2	EFC3600-0K40-3P4	EFC3600-0K75-3P4	EFC3600-1K50-3P4	EFC3600-2K20-3P4	EFC3600-4K00-3P4
Performance data										
Nominal power	[kW]	0.4	0.75	1.5	2.2	0.4	0.75	1.5	2.2	4
Rated continuous current	[A]	2.3	3.9	7	9.7	1.2	2.1	3.7	5.1	8.8
Motor nominal voltage		Three phase, 0 V ... mains voltage								
Output voltage		0 V ... mains voltage								
Output frequency		0...400 Hz								
Overload capacity		200% I _n for 1 s, or 150% I _n for 60 s								
Mains voltage	1 AC	1 AC 200 ... 240 V (-10%/+10%)								
	3 AC					3 AC 380 ... 480 V (-15%/+10%)				
Frequency		50 ... 60 Hz (±5%)								
Brake chopper / resistor										
Brake resistor		External								
Brake chopper		Internal								
Ambient conditions										
Permissible temperature (operation)		-10 ... +50 °C								
Permissible relative humidity (operation)		< 90%								
Max. installation height		Derating from 1000 m (1% of the power output per 100m)								
Category Total		IP20								
Functions										
Control technology		U/f								

Frequency converters

EFC 3600

Pulse width modulation (PWM), adjustable in 1-kHz increments	[kHz]	1 ... 15								
Modulation type		Magnetic flux PWM-modulation: SVPWM								
Speed control range	Without pulse encoder	1:50								
	With pulse encoder	–								
Start-up torque	U/f	100% at 1.5 Hz; 150% at 3 Hz								
Frequency resolution	Digital	0,01 Hz								
	Analog	Max. frequency x 0.1%								
V/F curve		Freely definable								
Ramps		Linear, S-curve								
DC brake	Start frequency	0 ... 50 Hz								
	Braking time	0 ... 20 s								
Automatic energy saving function		Load-dependent adaptation of V/f curve								
Automatic PWM frequency adaptation		Load-dependent adaptation of PWM frequency								
Integrated controller		Integrated step switching mechanism								
Frequency setting accuracy	Analog	0,1 %								
	Digital	0,01 %								
Regulators		PID								
Bus systems		Modbus								
		PROFIBUS (option in preparation)								
Status signal over digital output		Frequency								
Display		4-digit LED: frequency, output voltage, output current, etc.								
Status LED		Rotation direction and operating status								
Weight										
Mass	[kg]	0.96	1.24	1.61	2.35	1.18	1.26	1.52	2.25	2.36

Dimensions

Frequency converters

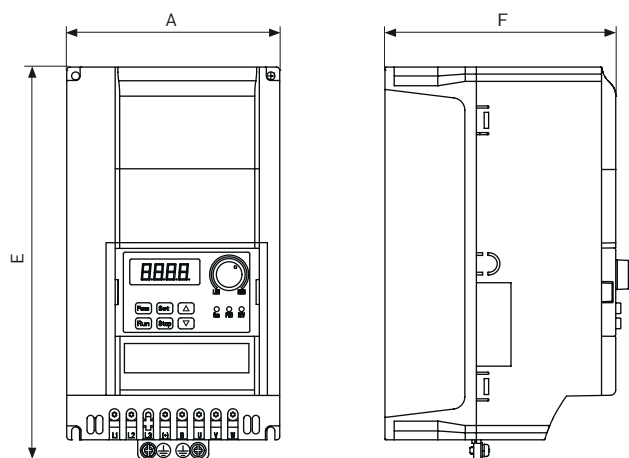
EFC 3600**Dimensions**

Type	A [mm]	E [mm]	F [mm]
EFC3600-0K40-1P2	90	146	105
EFC3600-0K75-1P2	95	156	120
EFC3600-1K50-1P2		196	125
EFC3600-2K20-1P2	120	221	130
EFC3600-0K40-3P4	95	156	120
EFC3600-0K75-3P4			
EFC3600-1K50-3P4		196	125
EFC3600-2K20-3P4	120	221	130
EFC3600-4K00-3P4			

Accessories

Type code	Description	Part No.:
FEAA01.1-RS485-RS232-NNNN-NN	RS232/RS485 adapter	R912001656
FRKB0002/005,0	Cable connecting the PROFIBUS adapter, 5 m	R912001757
FPCC01.1-EBNN-7P-NNNN	Operator panel IP20	R912003767
FELR01.1N-0K06-N400R-D-700-NNNN	Brake resistor 0.06 kW, 2 k Ω - EFC 3600 400 W, 400 V, 10% OT	R912004563
FELR01.1N-0K10-N400R-D-700-NNNN	Brake resistor 0.10 kW, 400 Ω - EFC 3600 400 W, 230 V, 20% OT	R912004564
FELR01.1N-0K10-N190R-D-700-NNNN	Brake resistor 0.10 kW, 190 Ω - EFC 3600 750 W, 230 V, 10% OT	R912004566
FELR01.1N-0K20-N190R-D-700-NNNN	Brake resistor 0.20 kW, 190 Ω - EFC 3600 750 W, 230 V, 20% OT	R912004567
FELR01.1N-0K20-N095R-D-700-NNNN	Brake resistor 0.20 kW, 95 Ω - EFC 3600 1.5 kW, 230 V, 10% OT	R912004569
FELR01.1N-0K40-N095R-D-700-NNNN	Brake resistor 0.40 kW, 95 Ω - EFC 3600 1.5 kW, 230 V, 20% OT	R912004570
FELR01.1N-0K30-N065R-D-700-NNNN	Brake resistor 0.30 kW, 65 Ω - EFC 3600 2.2 kW, 230 V, 10% OT	R912004572
FELR01.1N-0K50-N065R-D-700-NNNN	Brake resistor 0.50 kW, 65 Ω - EFC 3600 2.2 kW, 230 V, 20% OT	R912004573

Frequency converters

EFC 3600

Type code	Description	Part No.:
FELR01.1N-0K06-N2R00-D-700-NNNN	Brake resistor 0.06 kW, 400 Ω - EFC 3600 400 W, 230 V, 10% OT	R912004575
FELR01.1N-0K10-N2R00-D-700-NNNN	Brake resistor 0.10 kW, 2 k Ω - EFC 3600 400 W, 400 V, 20% OT	R912004576
FELR01.1N-0K10-N1R00-D-700-NNNN	Brake resistor 0.10 kW, 1 k Ω - EFC 3600 750 W, 400 V, 10% OT	R912004578
FELR01.1N-0K20-N1R00-D-700-NNNN	Brake resistor 0.20 kW, 1 k Ω - EFC 3600 750W, 400 V, 20% OT	R912004579
FELR01.1N-0K20-N500R-D-700-NNNN	Brake resistor 0.20 kW, 500 Ω - EFC 3600 1.5 kW, 400 V, 10% OT	R912004581
FELR01.1N-0K40-N500R-D-700-NNNN	Brake resistor 0.40 kW, 500 Ω - EFC 3600 1.5 kW, 400 V, 20% OT	R912004582
FELR01.1N-0K30-N330R-D-700-NNNN	Brake resistor 0.30 kW, 330 Ω - EFC 3600 2.2 kW, 400 V, 10% OT	R912004584
FELR01.1N-0K50-N330R-D-700-NNNN	Brake resistor 0.50 kW, 330 Ω - EFC 3600 2.2 kW, 400V, 20% OT	R912004585
FELR01.1N-0K50-N180R-D-700-NNNN	Brake resistor 0.5 kW, 180 Ω - EFC 3600 4.0 kW, 400 V, 10% OT	R912004587
FELR01.1N-1K00-N180R-D-700-NNNN	Brake resistor 1.0 kW, 180 Ω - EFC 3600 4.0 kW, 400 V, 20% OT	R912004588

Order information

Type code	Description	Part No.:
EFC3600-0K40-1P2-MDA-7P-NNNN	0,4 kW, 1 AC 200 ... 240 V, 50/60 Hz, 2,3 A	R912003758
EFC3600-0K75-1P2-MDA-7P-NNNN	0,75 kW, 1 AC 200 ... 240 V, 50/60 Hz, 3,9 A	R912003759
EFC3600-1K50-1P2-MDA-7P-NNNN	1,5 kW, 1 AC 200 ... 240 V, 50/60 Hz, 7 A	R912003760
EFC3600-2K20-1P2-MDA-7P-NNNN	2,2 kW, 1 AC 200 ... 240 V, 50/60 Hz, 9,7 A	R912003761
EFC3600-0K40-3P4-MDA-7P-NNNN	0,4 kW, 3 AC 380 ... 480 V, 50/60 Hz, 1,2 A	R912003762
EFC3600-0K75-3P4-MDA-7P-NNNN	0,75 kW, 3 AC 380 ... 480 V, 50/60 Hz, 2,1 A	R912003763
EFC3600-1K50-3P4-MDA-7P-NNNN	1,5 kW, 3 AC 380 ... 480 V, 50/60 Hz, 3,7 A	R912003764
EFC3600-2K20-3P4-MDA-7P-NNNN	2,2 kW, 3 AC 380 ... 480 V, 50/60 Hz, 5,1 A	R912003765
EFC3600-4K00-3P4-MDA-7P-NNNN	4 kW, 3 AC 380 ... 480 V, 50/60 Hz, 8,8 A	R912003766

Bosch Rexroth AG

Postfach 13 57
97803 Lohr, Germany
Bgm.-Dr.-Nebel-Str. 2
97816 Lohr, Germany
Tel. +49 9352 18-0
Fax +49 9352 18-8400
www.boschrexroth.com/electrics

Local contact information can be found at:

www.boschrexroth.com/adresen

The data specified above only serve to describe the product. As our products are constantly being further developed, no statements concerning a certain condition or suitability for a certain application can be derived from our information. The information given does not release the user from the obligation of own judgment and verification.

It must be remembered that our products are subject to a natural process of wear and aging.